

C1 Max – Efficient cleaning of large SLA parts without critical solvents

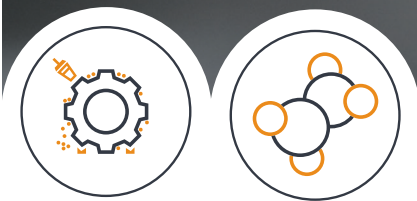
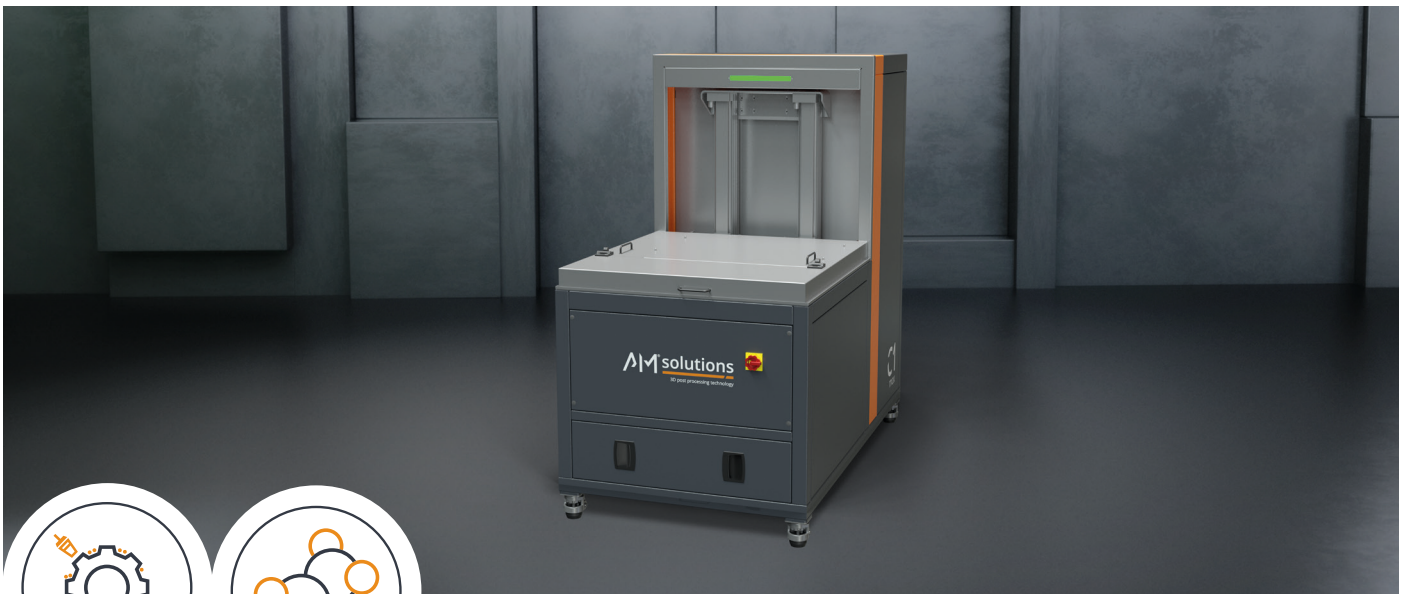

Cleaning

Polymers

Features & benefits

- Designed for large-scale parts up to 750 x 750 x 550 mm (l x w x h)
- Enhanced cleaning due to a perfect combination of chemical, thermal and mechanical processes
- Process allows much easier manual removal of support structures
- Lower operating costs and improved surface quality
- Enhanced process stability due to fill level monitoring and automatic dosing
- No use of critical solvents like IPA
- System automatically cleans used build platform making manual intervention unnecessary
- Fast and easy medium change due to integrated solution
- Ready to use for 3D Systems ProX 800 & SLA 750 with Accura Composite PIV, Accura Xtreme, etc.
- Upgradeable for use with 3D Systems SLA 825 Dual

Technical highlights

The C1 Max offers an automated, user-friendly and monitored post-processing process for 3D printed polymer parts up to 750 x 750 x 550 mm (l x w x h). The process for cleaning combines chemical, thermal and mechanical actions. This ensures that even the most intricate and confined areas are thoroughly and safely cleaned without compromising part integrity, and making unnecessary the use of critical solvents like IPA. In addition, the process allows much easier manual removal of

support structures, saving time and money. Different processing recipes can be stored for maximum flexibility. The system is also equipped with a level sensor and an automatic media replenishment system to ensure the highest and most consistent quality. The machine's sophisticated design allows easy loading and unloading of the build platform, as well as quick and easy media changes with an integrated solution.

Equipment layout

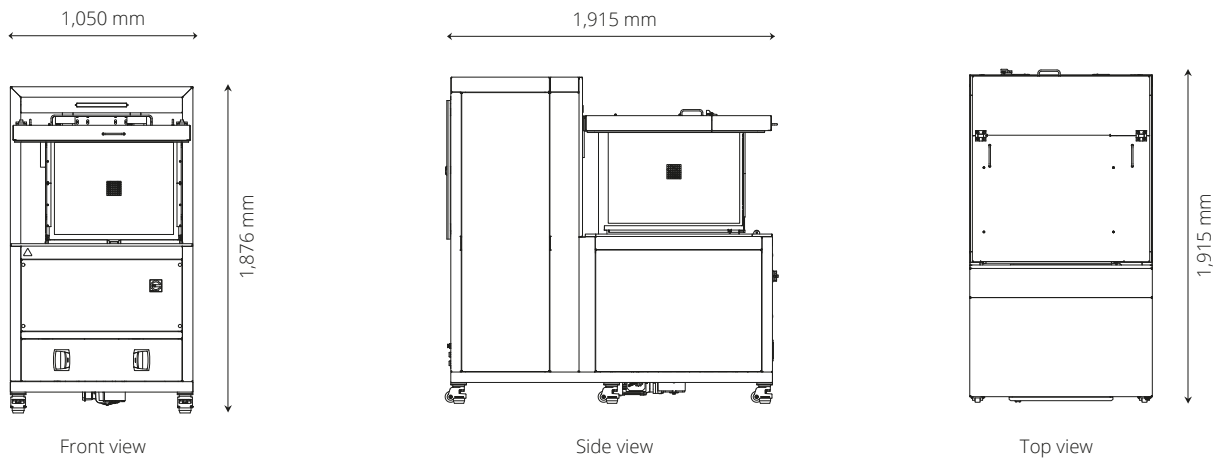

Equipment specifications

Technical data	Installation conditions
Dimensions of the processing space (l x w x h): 750 x 750 x 550 mm	Supply voltage: 400V / 3 ~/N/Pe, CEE connector 32A/5p
Fill volume: 575 litres	Control voltage: 24 V DC
Subsequent dosing: With integrated pump	Transport: stacker, movable by rollers
Recommendation: RAM-D1; RAM-D1M, RAM-D1R	Machine empty weight: ≈ 850 kg

Possible work piece dimensions (mm; l x w x h)

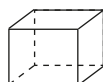

Minimum size: 20 x 20 x 20
 Maximum size: 750 x 750 x 550

